

**Transient Voltage Suppressor**

**Features**

- ◆ 100 Watts Peak Pulse Power per Line (tp= 8/20μs)
- ◆ Protects one I/O or power line
- ◆ Replacement for MLV (0603)
- ◆ Low Clamping Voltage
- ◆ Working Voltage: 5 V
- ◆ Low Leakage Current
- ◆ Solid-state silicon-avalanche technology
- ◆ IEC 61000-4-2 ( ESD ) ±30 KV contact ±30 KV Air
- ◆ IEC 61000-4-4 (EFT) 40A (5/50ns)
- ◆ IEC 61000-4-5 (Lightning 8/20μs): 8A

**Application**

- ◆ Cellular Handsets & Accessories
- ◆ Personal Digital Assistants (PDAs)
- ◆ Notebooks & Handhelds
- ◆ Portable Instrumentation
- ◆ Digital Cameras
- ◆ MP3 players

**Order Information**

Part Number	Package	Marking	Size (mm)	Delivery Form	Delivery Quantity
ESD5VFBD523	SOD-523	5XB	1.6X0.8X0.6	7" T&R	3000PCS/Tape

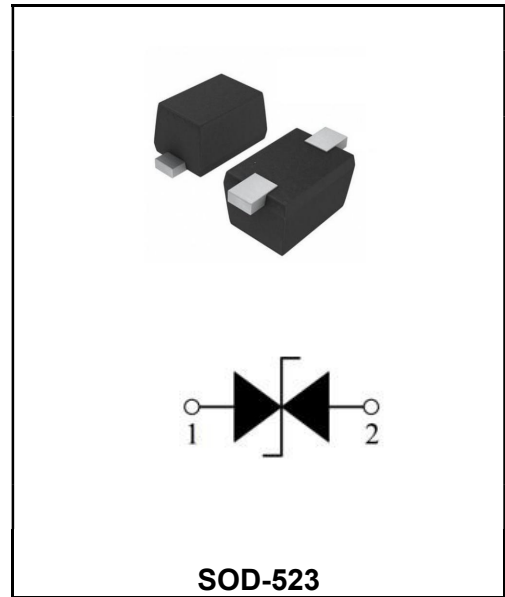

**Limiting Values(TA = 25 °C, unless otherwise specified)**

Symbol	Parameter	Conditions	value	Unit
P <sub>PP</sub>	Peak Pulse Power	tP = 8/20 μs	100	W
I <sub>PPM</sub>	Rated Peak Pulse Current	tP = 8/20 μs	8	A
V <sub>ESD</sub>	ESD per IEC 61000-4-2 ESD per IEC 61000-4-2	(Air) (Contact)	30 30	KV
T <sub>L</sub>	Lead soldering temperature		260(10seconds)	°C
T <sub>J</sub>	Junction Temperature	-	-55 to+150	°C
T <sub>stg</sub>	Storage Temperature Range	-	-55 to+150	°C

**Electrical Characteristics(TA = 25 °C unless otherwise specified)**

Symbol	Parameter	Conditions	Min	Typ.	Max	Unit
V <sub>RWM</sub>	Reverse Stand-Off Voltage		-	-	5.0	V
V <sub>BR</sub>	Breakdown Voltage	IT = 1mA	5.6	-	7.4	V
I <sub>R</sub>	Reverse Leakage Current	VRWM = 5 V; TA = 25 °C	-	-	0.1	uA
V <sub>C</sub>	Clamping Voltage	IPP=8 A, tP =8/20μs	-	-	9.5	V
C <sub>J</sub>	Junction Capacitance	VR = 0V, f = 1 MHz	-	15	-	pF

Typical Characteristics

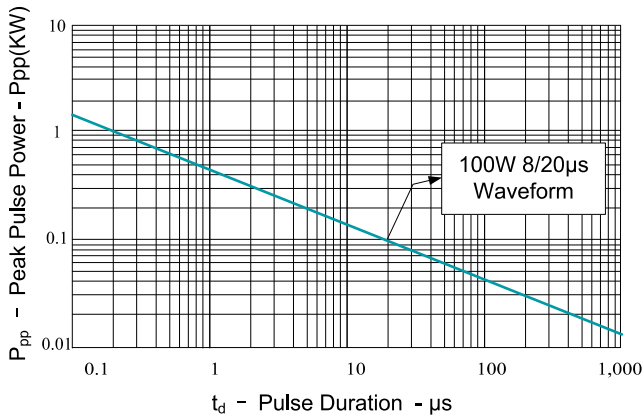

**Fig.1 Peak Pulse Power vs. Pulse Time**

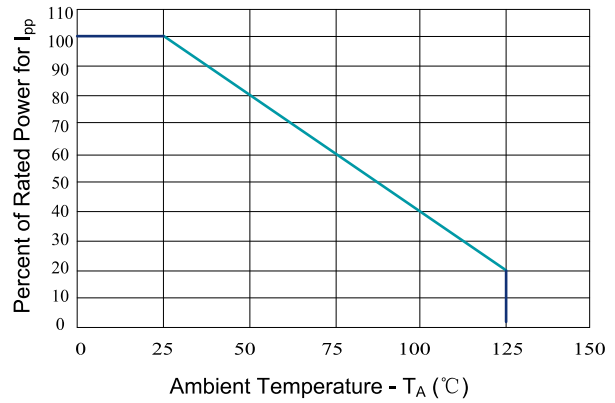

**Fig.2 Power Derating Curve**

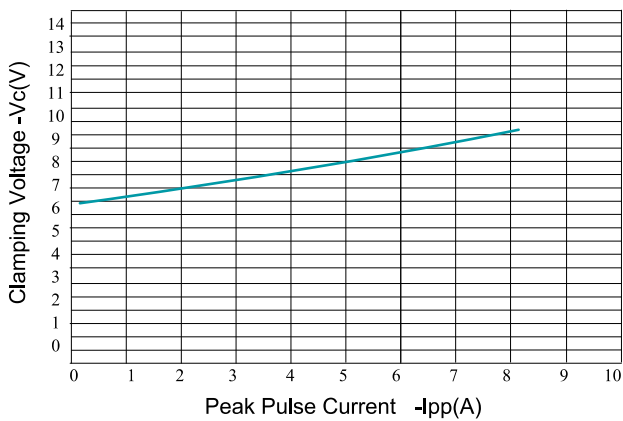

**Fig.3 Clamping Voltage vs. Peak Pulse Current**

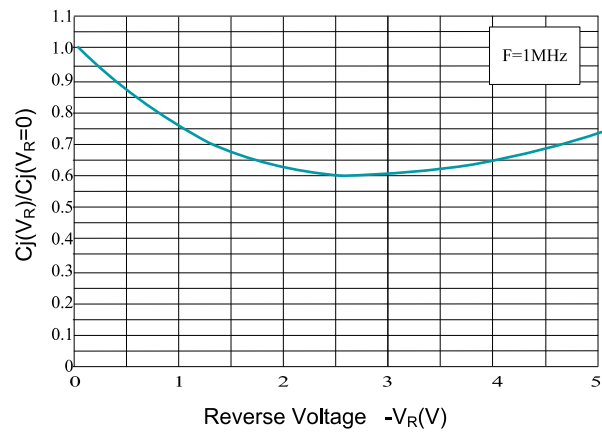

**Fig.4 Normalized Junction Capacitance vs. Reverse Voltage**

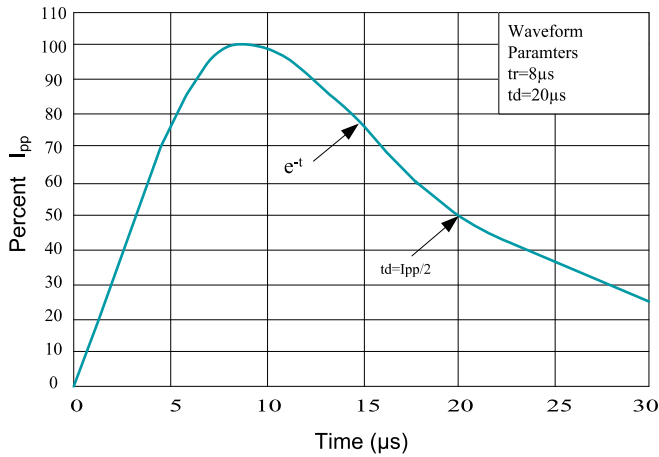

**Fig.5 Pulse Waveform**

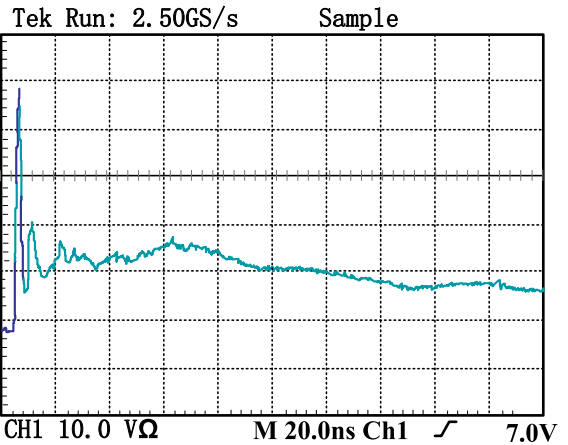

**Fig.6: ESD Clamping( 8kV Contact per IEC 61000-4-2)**

Electrical Parameters (T=25°C)

Symbol	Parameter
$V_{RWM}$	Reverse Stand-Off Voltage
$I_R$	Reverse Leakage Current
$V_{CL}$	Clamping Voltage
$I_{PP}$	Peak Pulse Current
$V_{TRIG}$	Reverse Trigger Voltage
$I_{TRIG}$	Reverse Trigger Current
$V_{HOLD}$	Reverse Holding Voltage
$I_{HOLA}$	Reverse Holding Current

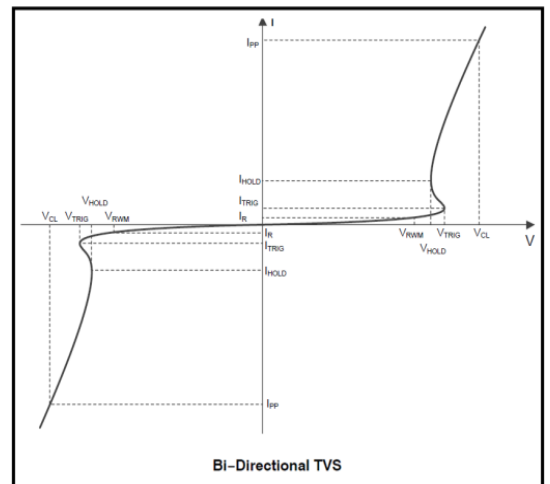

Package Dimension

**PACKAGE OUTLINE**

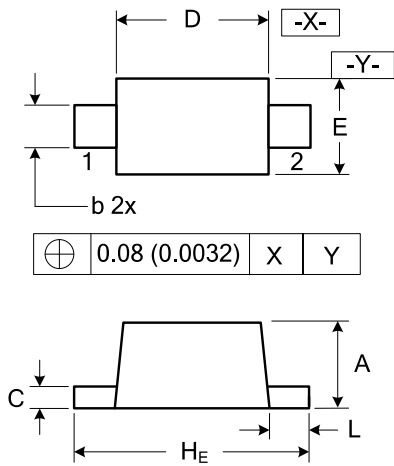

$\oplus$	0.08 (0.0032)	X	Y
----------	---------------	---	---

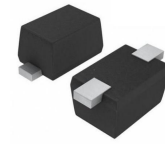

**SOD-523**

**DIMENSIONS**

SYMBOL	MILLIMETER		INCHES	
	MIN	MAX	MIN	MAX
A	0.50	0.70	0.020	0.028
b	0.25	0.35	0.010	0.014
C	0.07	0.20	0.0028	0.0079
D	1.10	1.30	0.043	0.051
E	0.70	0.90	0.028	0.035
H <sub>E</sub>	1.50	1.70	0.059	0.067
L	0.15	0.25	0.006	0.010

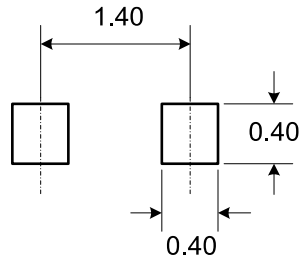

DIMENSIONS: MILLIMETERS

**Notes**

1. Controlling Dimensions in Millimeters.
2. Dimensions are exclusive of mold flash and metal burrs.